



Whitehall Manufacturing®
Manufacturer of Healthcare and Rehabilitation Products since 1946

Ligature Resistant Corterra™ Corner Basin ADA Compliant

Model WH3776



• Patented D840,523

WH3776L-WH3374L

INSTALLATION, OPERATIONS AND MAINTENANCE MANUAL



IMPORTANT

Important: Some options may slightly alter installation. To ensure proper installation review the Manual thoroughly and verify rough-ins before beginning any work. File this Manual with the owner or maintenance personnel upon completion of installation.

Industry standard wall backing, for wall hung fixtures, is required. Installer provided wall anchors and wall anchoring hardware must be appropriate for wall construction.

ANSI, UFAS or ADA compliance is subject to the interpretation and requirements of the local code authority and is the responsibility of the installer for verification.

Single Temp Valve Assembly: Recommended working water pressure is 30 PSI (2.07 bars) minimum to 100 PSI (6.89 bars) maximum. Maximum temperature is 130°F (54.4°C). Maximum outlet temperature recommended is 105°F (40.6°C). Valve assembly must be drained prior to being subjected to freezing temperatures. A checkstop is provided with this valve assembly.

T/P Mixing Valve Assembly: Recommended working water pressure is 30 PSI (2.07 bars) minimum to 100 PSI (6.89 bars) maximum. Maximum hot water temperature is 180°F (82°C). Temperature adjustment range is 85°F-115°F (29°C-46°C). Minimum hot water supply temperature must be 5°F (3°C) above desired set temperature. Valve assembly must be drained prior to being subjected to freezing temperatures. The valve assembly has checks integral to the inlets however, angle stops are to be provided by the installer.

Prior to installation, supply lines must be flushed of all foreign material such as pipe dope, chips, or solder. Debris or foreign material in water supply may damage valve.

Teflon tape is recommended on threaded connections where applicable to reduce the possibility of leaks.

Provide 110-120 VAC/60Hz/3A (MAX) electrical receptacle for factory supplied 120VAC/9VDC, 100mA plug-in transformer.

NOTE: Receptacle(s) must be wired to a GFCI protected circuit. Fixture must be earth grounded per N.E.C. (National Electrical Code).

Upon receiving, verify count and inspect packaging for obvious signs of damage or missing containers. If there are any issues upon receiving make note on bill of lading and report to carrier and manufacturer promptly. Remove fixture assemblies from packaging and ensure all parts are present before beginning installation. Do not discard packaging until all parts have been accounted for. Refer to Acorn terms, conditions of sales and warranty for more information.



ACCESSIBILITY OVERVIEW

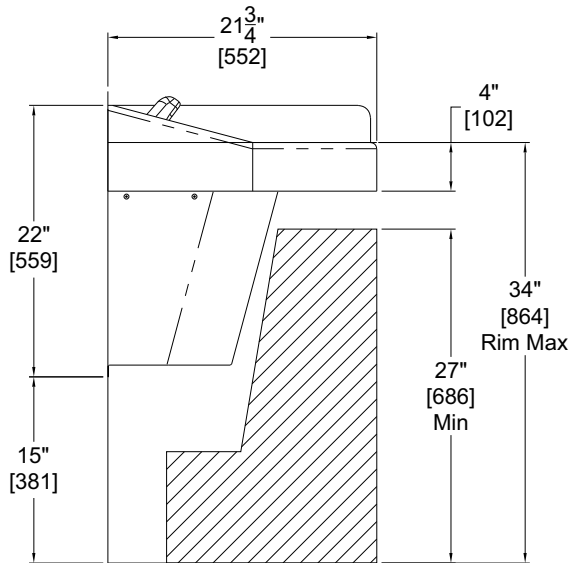

**ADA
Adult**

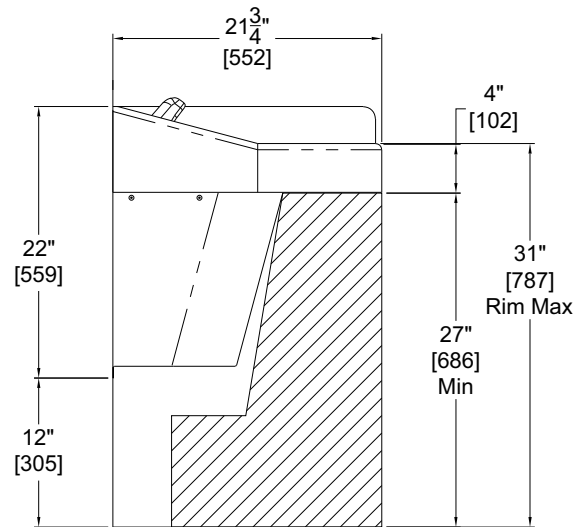

**ADA ages
6 thru 12**

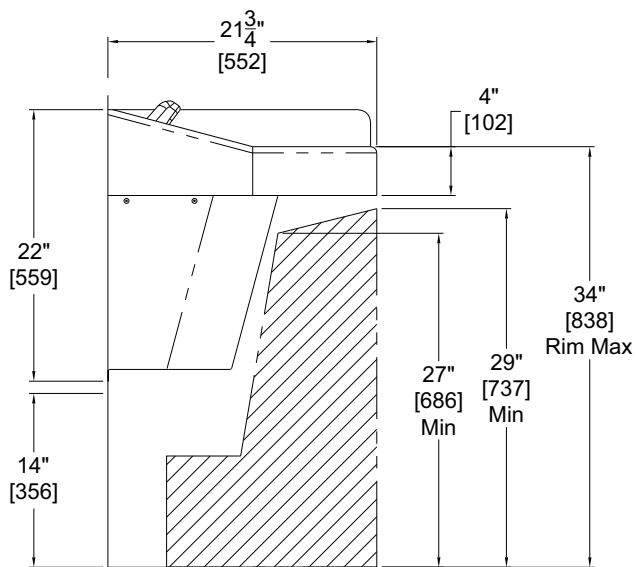

**CBC
(California Building Code)**

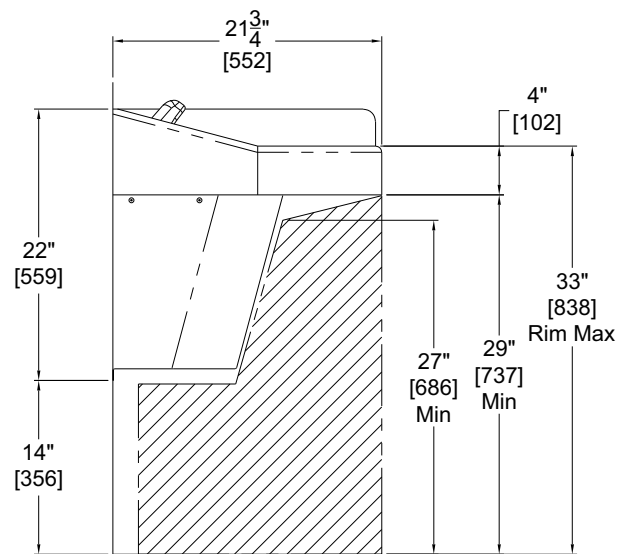

**OBC
(Ontario Building Code)**



DIMENSIONAL DATA (Left Corner Shown)

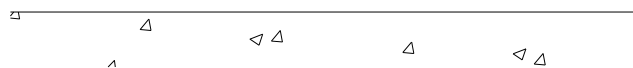
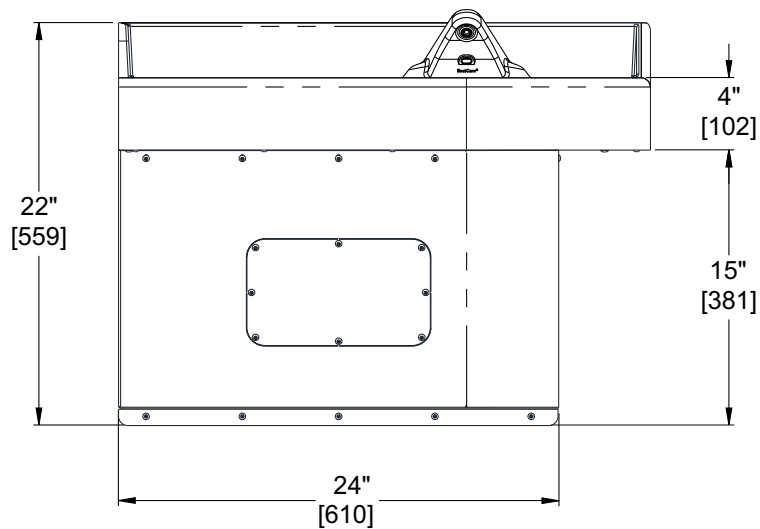
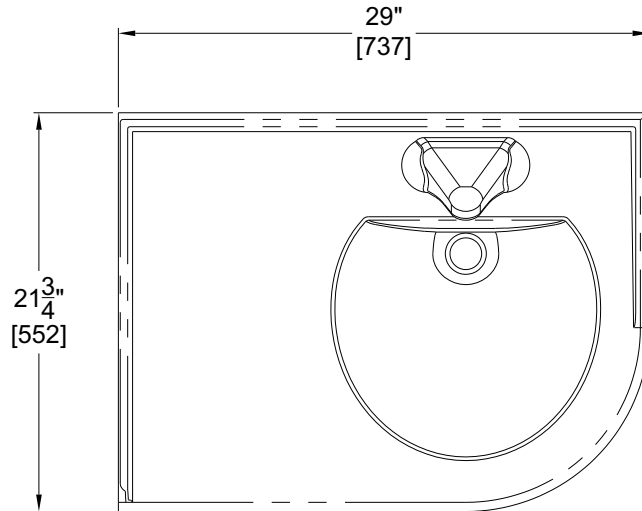





Instructions for Operation and Care of Best-Care WH3776

Required Items for Installation - Not Supplied

- ✘ Chalk Line
- ✘ Hammer
- ✘ Carpenters Level
- ✘ 1/2" NPS Outlet Angle Stops
- ✘ 1/2" NPS Flexible Supply Hose (For -MXTP Valves Only)
- ✘ 7/16" Hex Wrench
- ✘ Plumbers Putty
- ✘ Teflon Tape
- ✘ Fixture Wall Anchors and Anchoring Hardware (and Appropriate Tools) - For 3/8" (9 Places) & 1/4" Punching (3 Places)
- ✘ Driver For 1/4" Shank Bit - For Center Reject Bit
- ✘ 1/4" Slotted Tip Screwdriver For Metering Adjustment

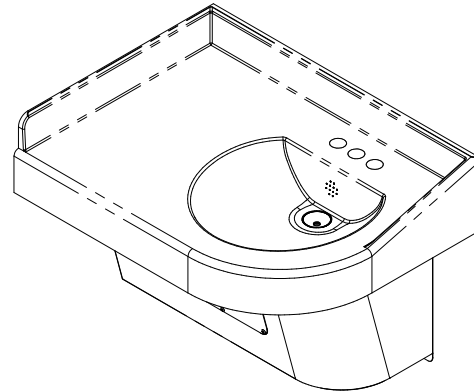
ROUGH-IN DIMENSIONS (Left Corner)



 NOTE: Fixture Weight is approx. 170 lbs. For Compatible In-Wall Support Carriers refer to J.R. Smith Model # 0816-M31

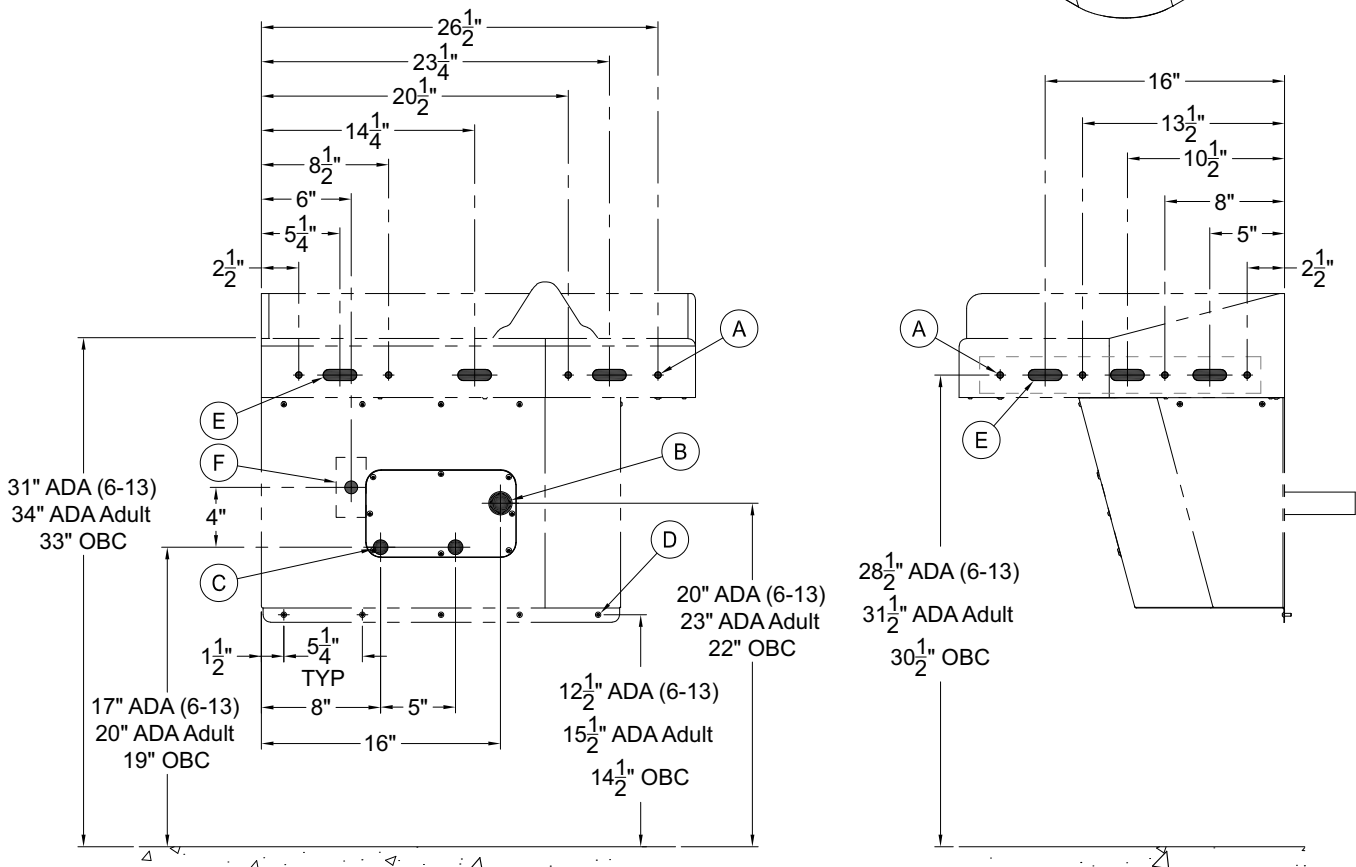

- (A) (8) 7/16" Diameter Mountings Holes provided. Fasteners and Wall Anchors are provided by others. Installer is to use Industry standards of Best Practice to suit wall type and construction, weight of fixture and application
- (B) 1-1/2" O.D. Tube Lavy Waste Outlet For Compression Joint
- (C) 1/2" NPS Hot & Cold Angle Stops (By Others)
- (D) (5) Ø1/4" Mounting holes. Provide Wall Backing for Fasteners and Wall Anchors (Provided by Others) to suit wall Construction.
- (E) (6) Ø3/4" x 2-1/4" Slots for optional 5/8" x 6" Long UNC Carrier Support Studs. Reference JRSMITH 0816-M31
- (F) 120VAC, 60HZ, 3A (MAX) GFCI Protected, Electrical Receptacle



ROUGH-IN DIMENSIONS (Right Corner)



NOTE: Fixture Weight is approx. 170 lbs.
For Compatible In-Wall Support Carriers
refer to J.R. Smith Model # 0816-M31

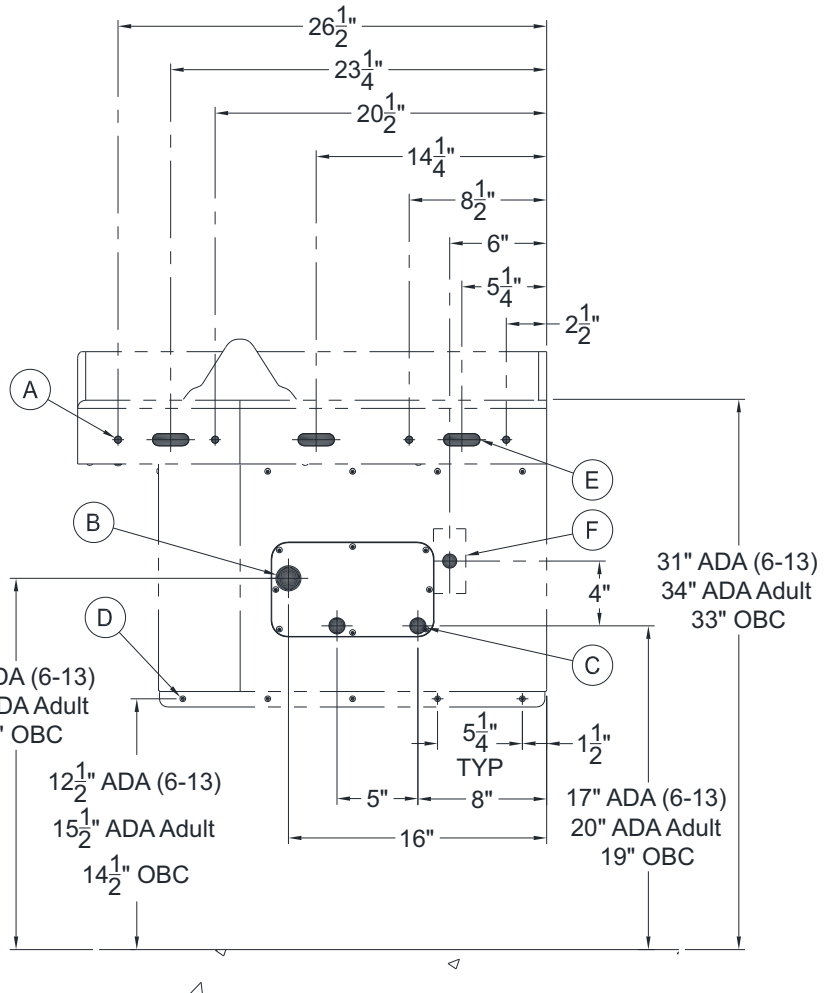
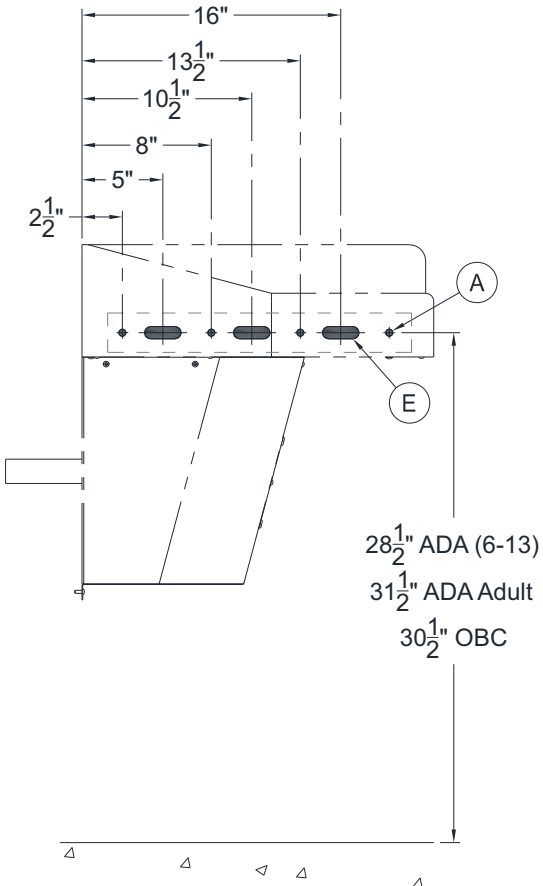
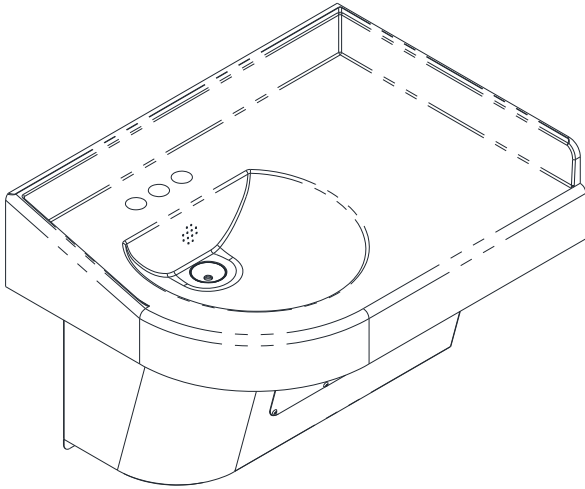

- (A) (8) 7/16" Diameter Mountings Holes provided. Fasteners and Wall Anchors are provided by others. Installer is to use Industry standards of Best Practice to suit wall type and construction, weight of fixture and application
- (B) 1-1/2" O.D. Tube Lavy Waste Outlet For Compression Joint
- (C) 1/2" NPS Hot & Cold Angle Stops (By Others)
- (D) (5) Ø1/4" Mounting holes. Provide Wall Backing for Fasteners and Wall Anchors (Provided by Others) to suit wall Construction.
- (E) (6) Ø3/4" x 2-1/4" Slots for optional 5/8" x 6" Long UNC Carrier Support Studs. Reference JRSMITH 0816-M31
- (F) 120VAC, 60HZ, 3A (MAX) GFCI Protected, Electrical Receptacle



ROUGH-IN DIMENSIONS (MC-FLR FIXTURE SUPPORT FLOOR MOUNTED TYPE)

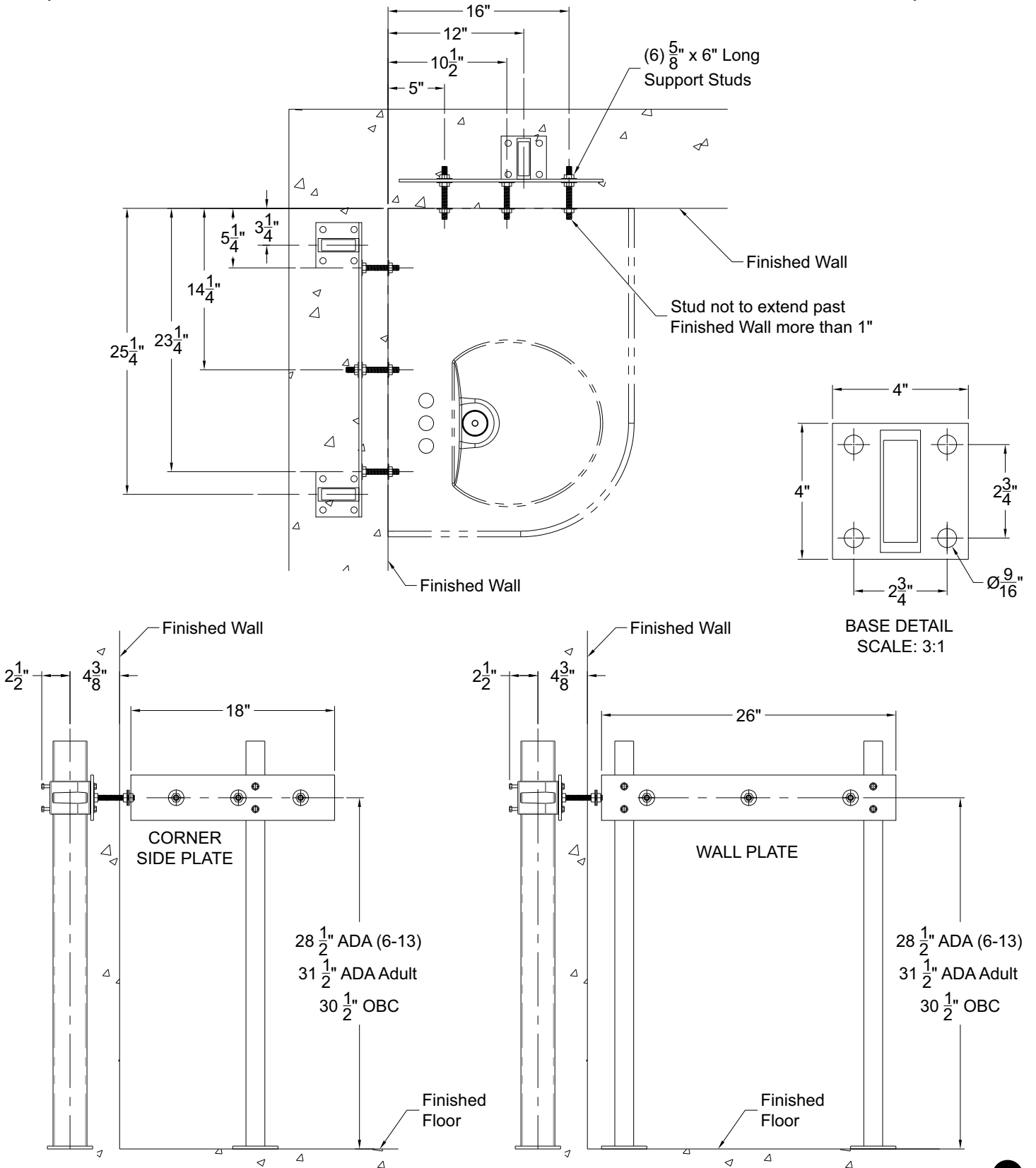



FIXTURE ANCHORING

- 1 Disassemble Bottom Cover from Deck Assembly by removing #10-32 x 1/2" (Qty. 7) and 1/4-20 x 1/2" (Qty. 4) Hex Button Head Center Reject Screw. Locate and anchor the basin to the finished wall using mounting hardware by others, refer to dimensional data for rough-in information. Assemble waste assembly and make appropriate connections. Test for leaks for usage.



HINT: It may be advantageous to install Faucet prior to wall mounting.

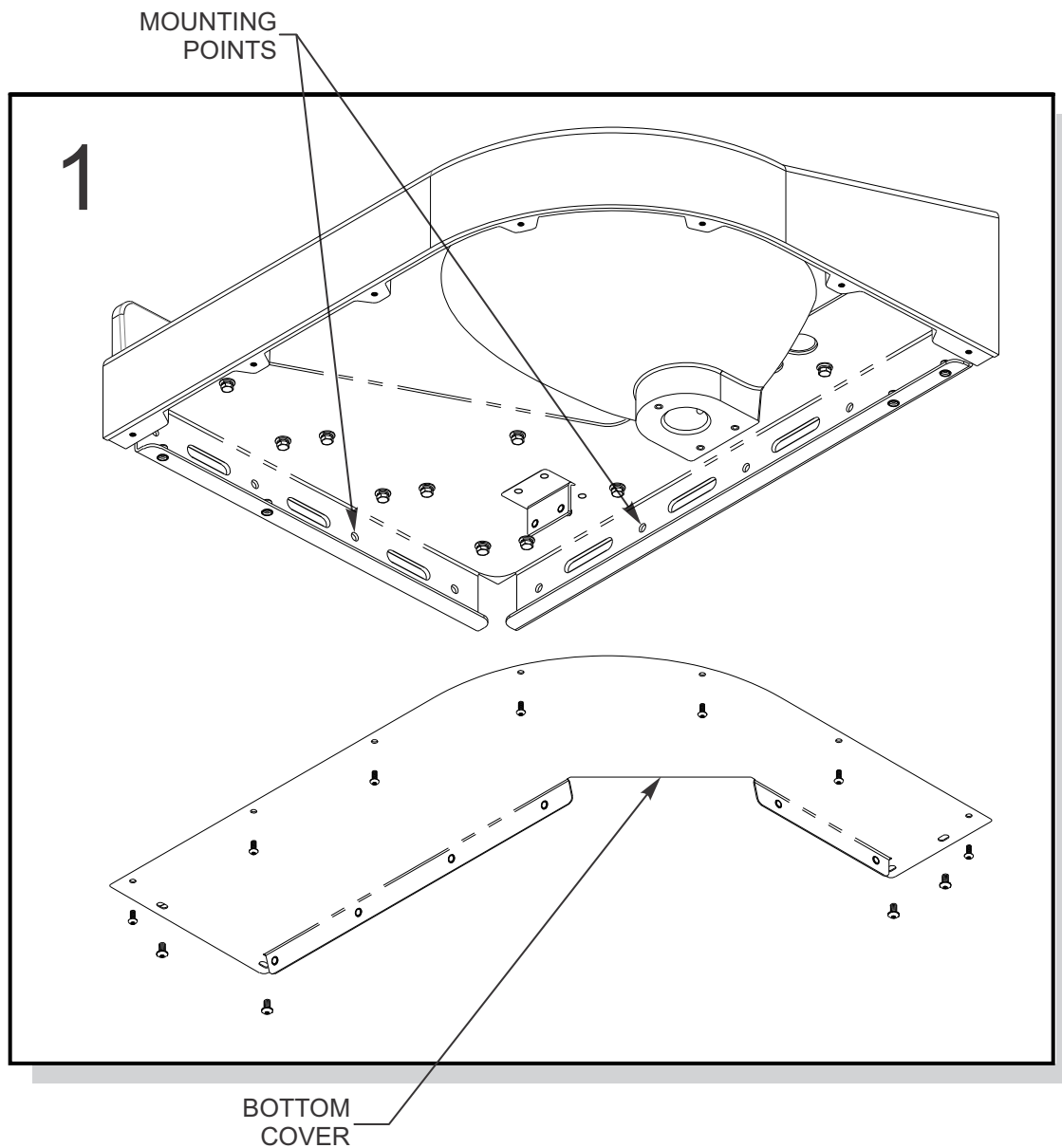



WASTE ASSEMBLY

 HINT: Teflon tape is recommended on all Threaded Waste and Supply Connections.

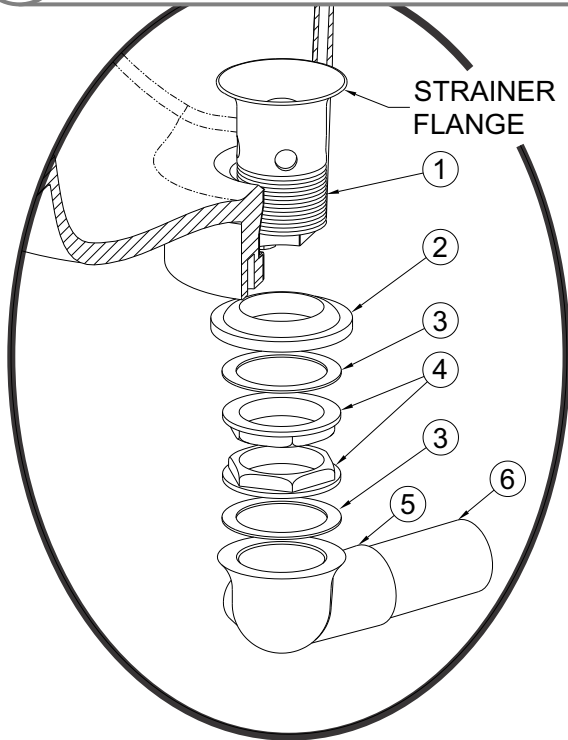

2 Install Strainer to Basin using plumbers putty on underside of grid strainer flange. From beneath Basin, assemble Gasket, Washer and Jam Nut as shown to Strainer and tighten securely. Add Close Elbow to Strainer Assembly as indicated.

- ① Strainer w/ 1-1/2"-16 UNE Threads
- ② Rubber Gasket
- ③ Flat Fiber Washer
- ④ 1-1/2" -16 UNI Rough Chrome Brass Jam Nut
- ⑤ 1-1/2"-16 x 1-1/4" UNI Close Ell with 3/8" NPT Clean-Out Plug
- ⑥ Waste Outlet Connection

 NOTE: Waste Assembly may require field cutting and fitting by the installer.

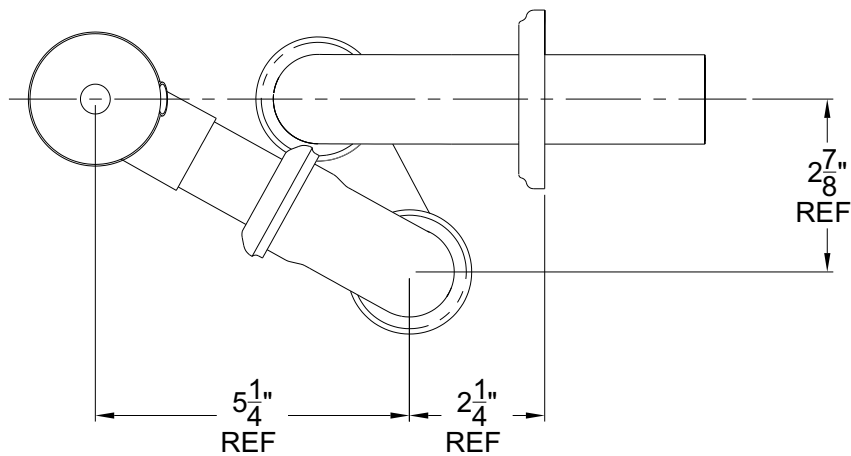

3 Assemble waste piping using teflon tape on all threaded connections and make up waste connections to 1-1/2" P-trap.



VALVE INSTALLATION

! IMPORTANT

Before making up the supply connections, the supply lines must be flushed of all foreign material such as pipe dope, pipe chips, solder, sand, etc.

DUAL TEMP. WITH -MXTP VALVE

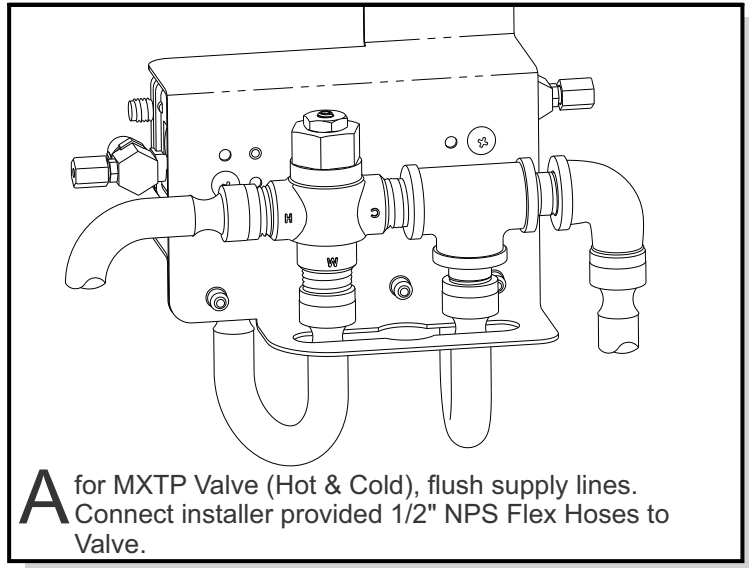

-03-M SINGLE TEMPERATURE METERING VALVE

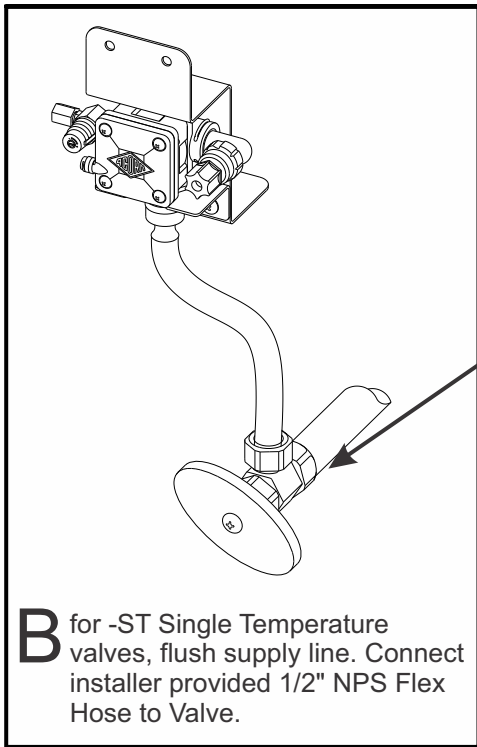

Supply Shut-Off Valve shown is provided by others.



VALVE INSTALLATION & ADJUSTMENT

Valve Assembly Installation:

NOTE: Installation should be in accordance with accepted plumbing practices.

- 1) Locate suitable place for mounting the Valve Assembly. Valve Assembly should be accessible for service and adjustment and as close to the point-of-use as possible. Wall Anchors and Anchoring Hardware are by others.
- 2) Connect hot and cold water to Supply Valve using 1/2" NPT connections.
- 3) Connect outlet of Tempering Valve to Spout(s) using 1/4" O.D. Tube connections provided.
- 4) Turn on hot and cold water supplies. If any leaks are observed, hand-tighten connections as necessary to stop leaks before proceeding.
- 5) Turn on fixture and allow water to flow for 2 minutes. Measure water temperature at outlet. If water is not at desired temperature, adjust as necessary.

 **HINT:** Angle Stops are recommended and is the responsibility of the installer.

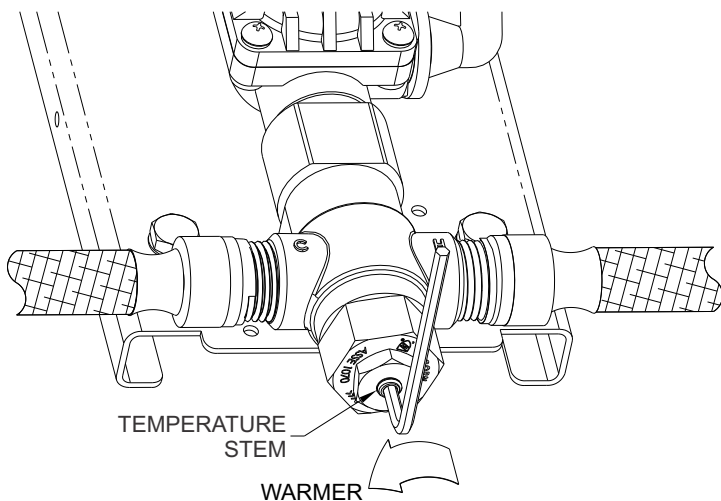

 **IMPORTANT**
Flush supply lines of all foreign material such as pipe dope, pipe chips, solder, sand etc. before making up supply connections.

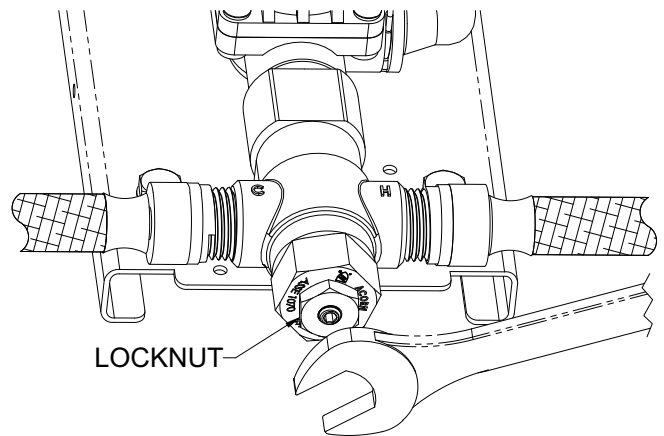
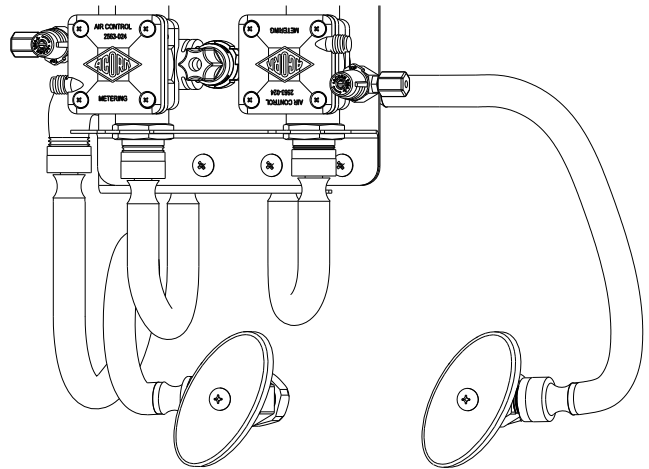

Temperature Adjustment:

NOTE: Factory set temperature is 105° F

- 1) Loosen Locknut.
- 2) Turn on fixture and run water for at least 2 minutes. Allow supply temperature to stabilize.
- 3) Turn temperature stem counter-clockwise for hotter or clockwise for colder outlet temperature.
- 4) Tighten Locknut to prevent accidental or unauthorized temperature adjustment.
- 5) Re-check outlet temperature.



VALVE CONNECTIONS

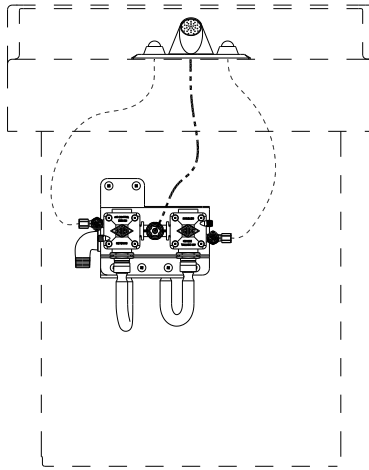

----- 1/8" O.D. AIR TUBING
 _____ 1/4" O.D. WATER TUBING

! IMPORTANT

Leave a minimum 1/4" of Polyethylene Tubing through the Ferrule Nut on the Pushbutton Assembly. This is necessary to ensure proper tubing connection.

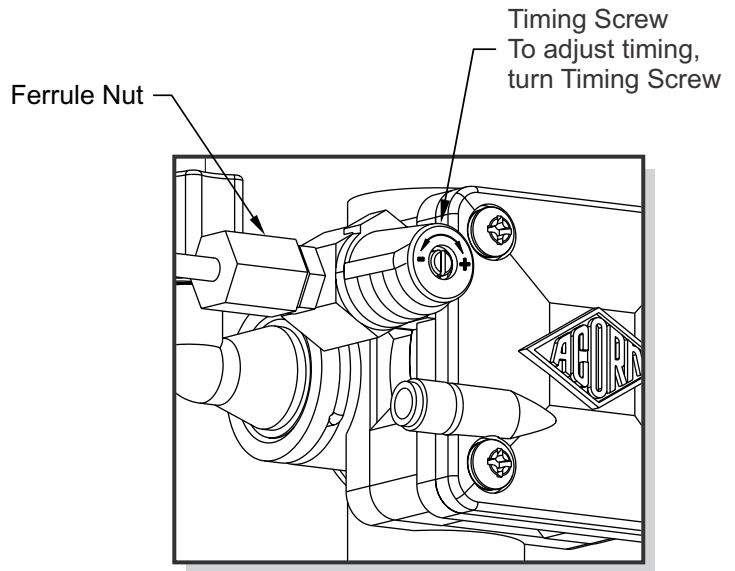
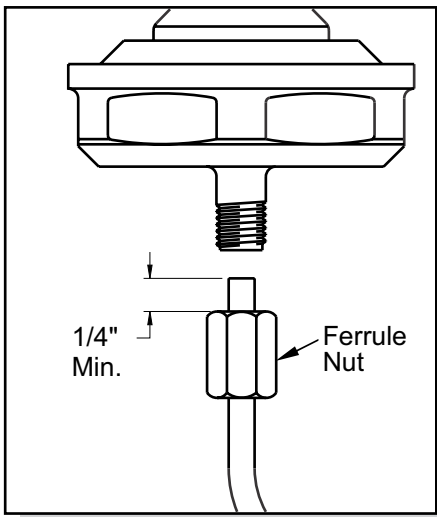

Turn Timing Screw clockwise to increase timing.

! IMPORTANT

Do not over-tighten ferrule nuts.



SENSOR OPERATION & CONNECTIONS

-SO Sensor Operation Range Adjustment

1. Make sure Power Supply is disconnected from Sensor and make short circuit on red wires. See DETAIL A.
2. Connect Power Supply to Sensor. Red light should be flashing.
3. Move hand in front of sensor to distance of 2" to 4" within 5 seconds and wait until red light flashes quickly.
4. Move hand to desired sensing distance. See DETAIL B.
5. Hold hand at desired sensing distance until red light stops flashing and Solenoid activates. See DETAIL C.

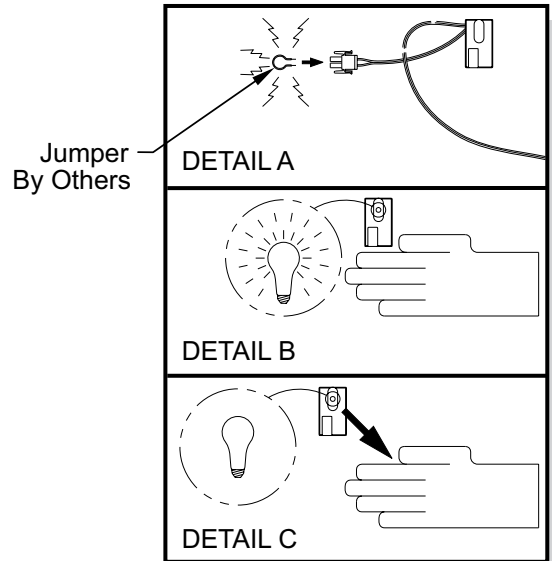

-SO Sensor Operation or -PPZ Programmable Piezo Pushbutton

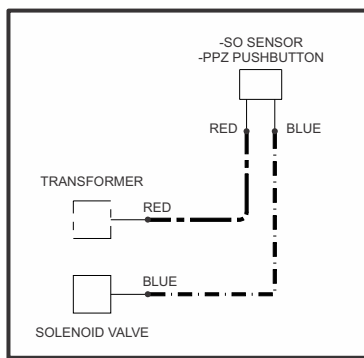
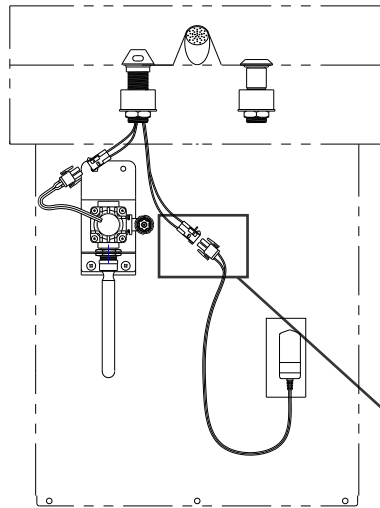

! IMPORTANT

Transformer must be plugged into a GFI protected circuit. Fixture must be earth grounded per N.E.C. or applicable codes.

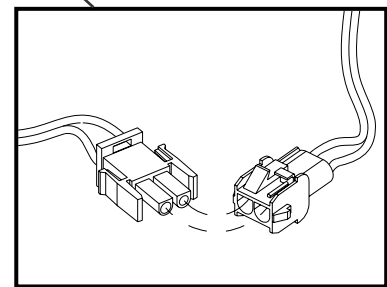



P-TRAP COVER INSTALLATION

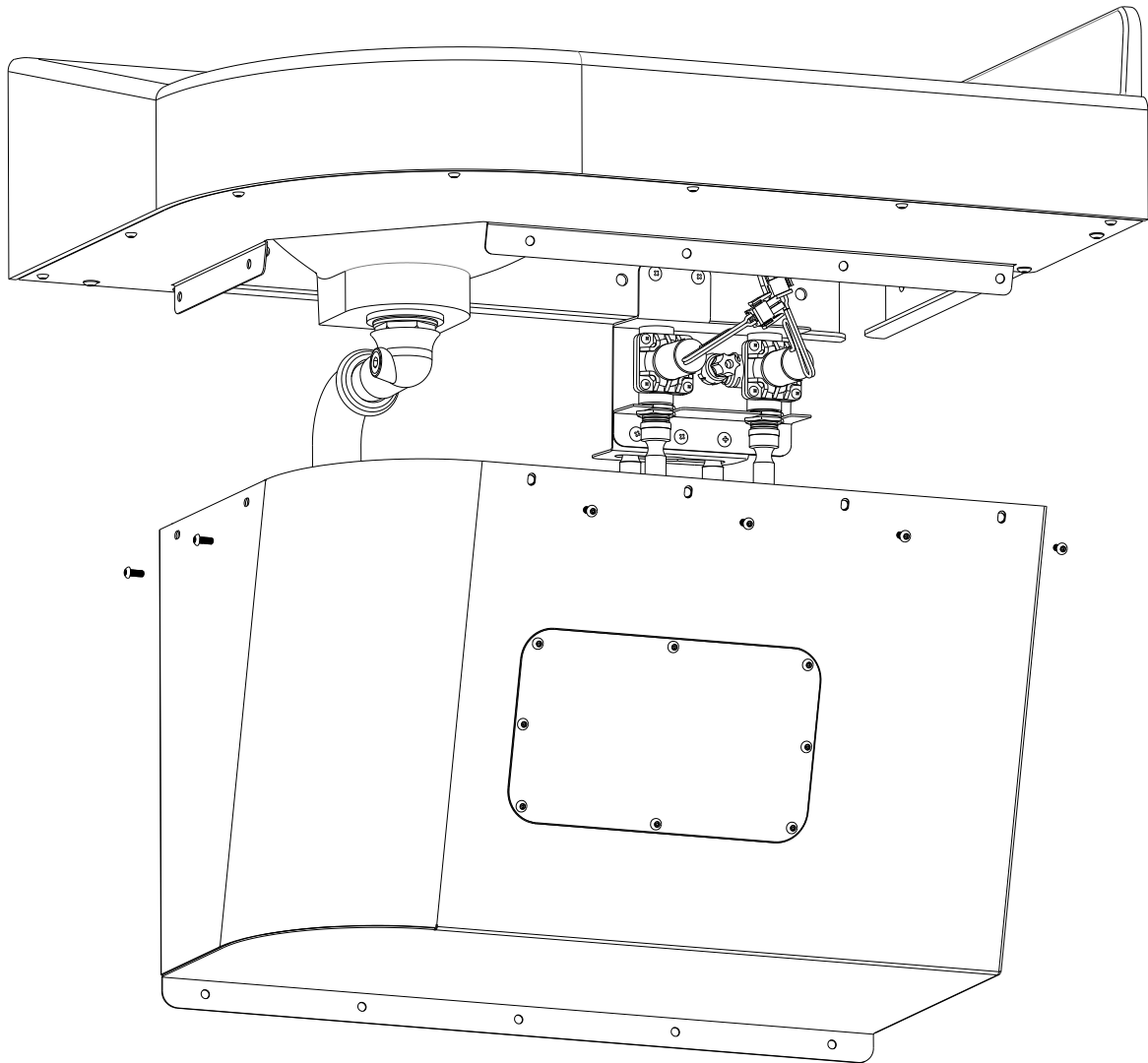

Install P-Trap Cover using #10-32 UNF x 1/2" Center Reject Hex Head Screws provided.
Secure bottom of P-Trap Cover to wall with Wall Anchors to suit wall construction (by others).



TROUBLESHOOTING FOR OPTIONAL PUSHBUTTON OPERATED VALVES

Normal Valve Function: Pushbutton Operated Valve has an adjustable flow time from 5 to 60 seconds.

CONDITION: WATER DOES NOT FLOW

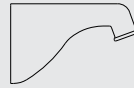

<i>Probable Cause</i>	<i>Solution</i>
Water main closed	Open water main
Checkstops closed	Open checkstops
Debris or scale in Checkstop Strainer	Remove Checkstop Strainer and clean
Air leaks from 1/8" O.D. Tubing or Fittings	Replace damaged Tubing or Fitting
Pushbutton Air Diaphragm leaks	Replace Pushbutton Air Diaphragm
Servomotor Diaphragm center hole is blocked	Remove blockage
Servomotor Upper Diaphragm is damaged	Replace Servomotor Upper Diaphragm
Low or no water pressure at supplies	Increase water pressure to 30 PSI minimum

CONDITION: WATER DRIPS, WON'T SHUT OFF

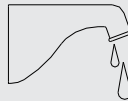

<i>Probable Cause</i>	<i>Solution</i>
Servomotor Diaphragm offset hole is blocked	Remove blockage
Servomotor Seat is damaged	Replace Servomotor seat
Servomotor Plate or Diaphragm is obstructed	Remove cause of obstruction
Servomotor Timer Assembly is damaged	Replace Servomotor Timer assembly

CONDITION: REDUCED WATER FLOW

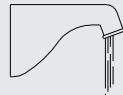

<i>Probable Cause</i>	<i>Solution</i>
Valve Riser Tubing is crimped	Straighten Valve Riser Tubing
Debris or scale in Checkstop Strainer	Remove Checkstop Strainer and clean
Blockage in Valve Flow Control	Remove blockage
Low water pressure at supplies	Increase water pressure to 30 PSI minimum
Lime deposits in hot water pipes	Remove lime deposits with appropriate cleaning solution

CONDITION: PREMATURE WATER SHUT OFF

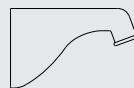

<i>Probable Cause</i>	<i>Solution</i>
Air leaks from 1/8" O.D. Tubing or Fittings	Replace damaged Tubing or Fitting
Pushbutton Air Diaphragm leaks	Replace Pushbutton Air Diaphragm



CARE, CLEANING, AND REPAIR OF CORTERRA SOLID SURFACE

Acorn's Corterra densified solid surface material is composed of recycled Solid Surface Polymer Resin, Aluminum Trihydrate and Fillers. It is resistant to stains, impact and burns and complies with ANSI Z124.3. It is attractive, durable and easy to maintain.

Routine Cleaning

Corterra should be kept clean at all times. If maintained, Corterra surfaces will retain their new, clean appearance indefinitely. Wash with a non-abrasive all purpose cleaner and water, then rinse. Wipe dry. (Never use cleaners with strong chemicals such as toilet bowl cleaners, rust removers, ceramic cook top cleaners, laquer thinners or oven cleaners). To remove persistent stains use a Scotch Brite pad and an abrasive cleaner or a solution of household bleach and water (1 part water to 1 part bleach).

Repairing Surface Damage

Surface damage, such as minor chips, scratches, burn marks and graffiti can be repaired with a fine grit abrasive cleanser, such as a Scotch-Brite pad or fine grit sandpaper. For more serious physical damage caused by vandals, an Acorn Solid Surface Repair Kit is available. Contact the factory for details. Refer to drawing #9927-160-002.

CARE AND CLEANING OF ENVIRO GLAZE/ POWDER COATING

Recommended Cleaning Materials:

- Sponge - natural or artificial
- Nylon or other soft-bristle brush
- Microfiber Cloth

Recommended Cleaning Solutions:

- Hand dishwashing liquid / soft water solution
- Mild soap / soft water solution
- Soft-Scrub®
- Comet Soft Cleanser®
- Clorox®
- Scrubbing Bubbles® Gel

Normal Cleaning:



For everyday cleaning, use a sponge or cotton cloth soaked in mild soap and wipe-down surface. In industrial or marine locations, close attention should be paid to regular care due to harsher atmosphere.

To remove dirt and debris:

Fixture should be periodically washed with a diluted solution of a mild non-abrasive detergent (e.g. Dawn®) in cold or ambient temperature water using a soft non-abrasive cloth or chamois.



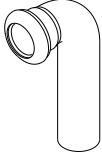
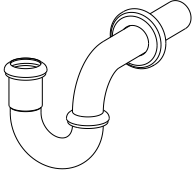
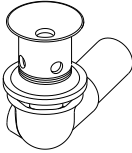

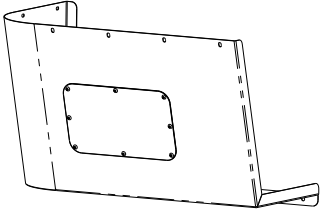
COMPONENTS & REPAIR PARTS

Description	Part No.	Diagram
COMBINED WASTE ASSEMBLY		
1-1/4" OD Waste Bend Connection	4970-180-001	
1-1/2" OD Tubular P-Trap	4953-001-000	
Ligature Resistant Elbow Strainer	4926-080-000	
1-1/2" Nylon Compression Washer	0431-125-000	
1-1/2" IPS x 1-1/2" Slip Nut	4970-059-000	
ENCLOSURES		
P-Trap Cover	Left BU5CRN42-002 Right BU5CRN40-002 (Shown)	

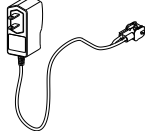
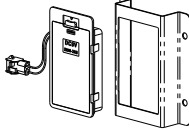
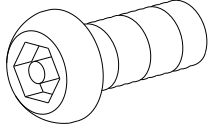
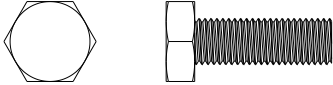

COMPONENTS & REPAIR PARTS

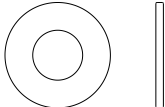
Description	Part No.	Diagram
ELECTRONIC HARDWARE		
9VDC Plug-In Transformer	0710-735-001	
9 VDC Battery-Pak Assy (6 AA Batteries Not Included) Battery-Pak Mounting Bracket	0710-358-001 6155-013-199	
ASSEMBLY HARDWARE		
#10-32 x 1/2" S/S Hex C/R Button Head Screw, White	0112-044-000	
1/4"-20 UNC x 3/4" Hex Head Cap Screw	0206-008-000	
1/4" Lock Washer	0337-050-000	
1/4" Flat Washer	0331-005-000	



Certain optional Best-Care® Faucet Parts are included for reference. When specified, refer to selected Faucet Model for additional details.

COMPONENTS & REPAIR PARTS

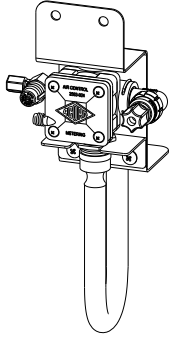
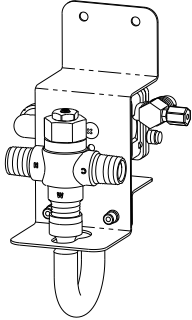
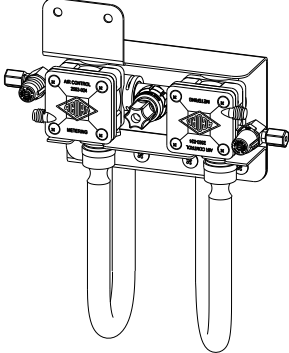
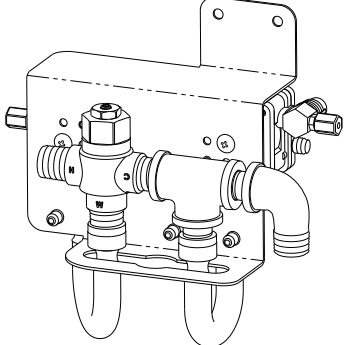
Description	Part No.	Diagram
VALVE		
<p>-WH3376L</p> <p>Optional -03-M Single Temp, Metering Valve Assembly</p>	2590-900-001	
<p>-WH3376L-MXTP</p> <p>Optional -03-M-MXTP, Single Temp, Temperature-Pressure Balancing Mixing Valve, ASSE 1070 Compliant</p>	2590-901-001	
<p>-WH3377L</p> <p>Optional -04-M Hot & Cold, Metering Valve Assembly</p>	2590-910-001	
<p>-WH3377L-MXTP</p> <p>Optional -04-M-MXTP, Hot & Cold, Temperature-Pressure Balancing Mixing Valve, ASSE 1070 Compliant</p>	2590-911-001	



COMPONENTS & REPAIR PARTS

Description	Part No.	Diagram
VALVE		
<p>-WH3377L-PPZ -WH3377L-WSF-SO -WH3375L-WSF-SO</p> <p>Optional Electronic Metering Valve Assembly, Single Temperature</p>	2590-905-001	
<p>-WH3377L-PPZ-MXTP -WH3377L-WSF-SO-MXTP -WH3375L-SO-MXTP</p> <p>Optional Electronic Metering Valve Assembly, Single Temp, Temperature-Pressure Balancing Mixing Valve, ASSE 1070 Compliant</p>	2590-906-001	
<p>-WH3377L-PPZ</p> <p>Optional Electronic Metering Valve Assembly, Hot and Cold</p>	2590-915-001	
<p>-WH3377L-PPZ-MXTP</p> <p>Optional Electronic Metering Valve Assembly, Hot and Cold, Temperature-Pressure Balancing Mixing Valve, ASSE 1070 Compliant</p>	2590-916-001	